

**16 kW**  
60 Hz / 1800 RPM

**12 kW**  
50 Hz / 1500 RPM

## Service Side

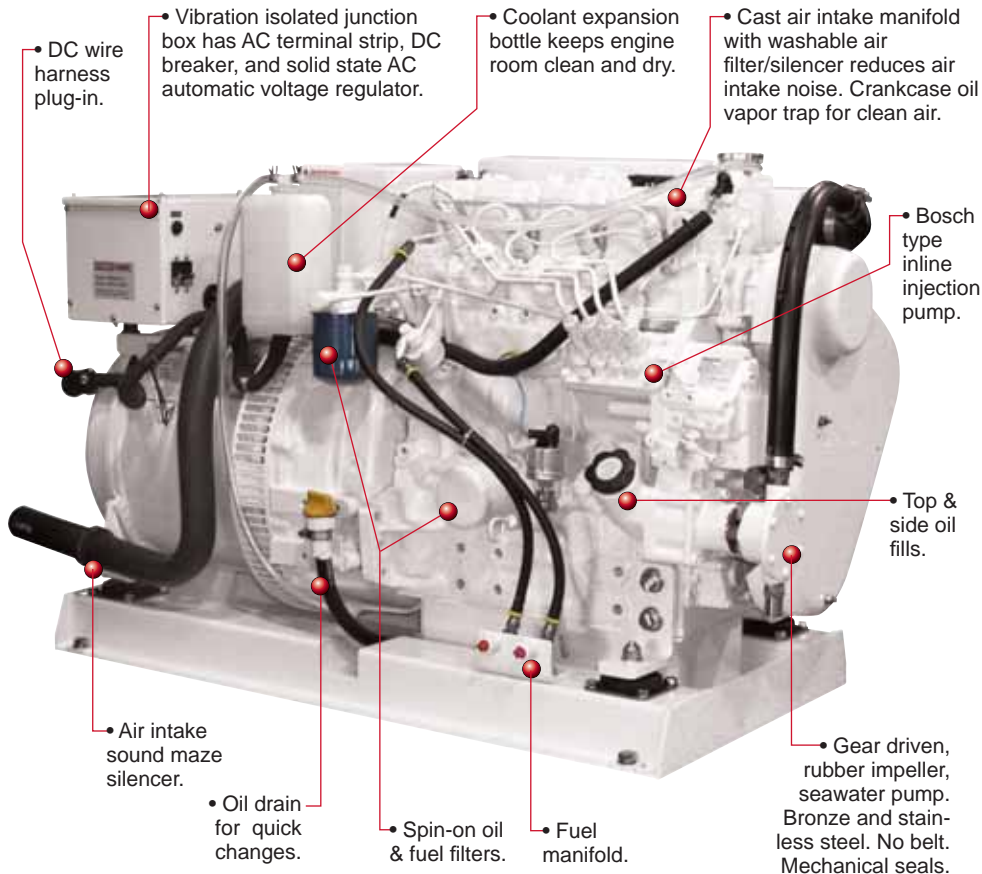

## Non-Service Side

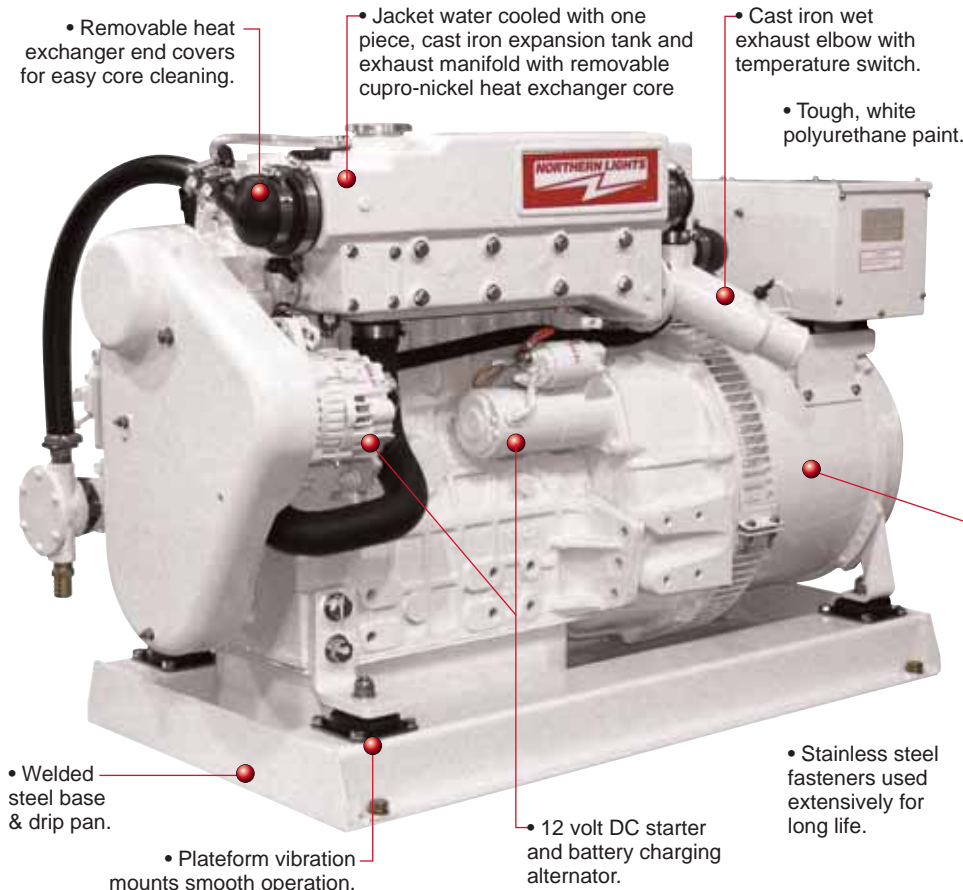

A vessel that needs 16 to 20 kW is large enough that continuous power is critical to its operation. Unfortunately, most sets in this range have small displacement, light duty diesels that can't stand up to heavy use. Some even need turbochargers to compensate for their small displacement.

The M844W2 is different. Powered by a naturally aspirated, four cylinder diesel, this set has the low end torque needed to start big electric motors. Yet it weighs only 890 pounds and is compact in size. The M844W2 meets US EPA Tier II emission standards protecting the environment you enjoy.



Vibration isolation mounts, cast air intake manifold and sound maze intake silencer make the set remarkably smooth and quiet. A sound enclosure is available.

Operation and maintainance are simple. A 20 foot wire harness and control panel lets you run the set from your boat's bridge. The engine's DC electrical system uses reliable relays instead of delicate printed circuit boards. If a failure should occur, you can simply plug in an inexpensive relay. All service points are on one side within easy reach. The sea water pump's location makes impeller changes a snap.

Need hydraulic power? Add an optional front PTO (power take off) with an electric clutch. At the touch of a button you have power for your bowthruster and winches without starting your main engine.



## Featuring new W-Series generator

The new W-Series generator end is a major step in our constant quest to give you the best generator set on the market. It features an auxiliary stator winding that supplies separate and stable power to the Automatic Voltage Regulator (AVR). The results are impressive:

- Classification society compliance.
  - Real 300% short circuit capability.
  - Improved AC circuit breaker performance.
- See your dealer for more information.

<b>AC Output<sup>1</sup></b>	
<b>16 kW</b>	60 Hz, 1800 RPM, 1 Ph, 1.0 PF, 120-240 V/66.6 A, 120 V/133 A
<b>12 kW</b>	50 Hz, 1500 RPM, 1 Ph, 1.0 PF, 220 V/54.4 A
Optional	Three Phase with 0.8 PF
Voltage regulation	±1%
<b>Lugger L844-2 Engine</b>	
Type	Vertical inline 4 cylinder diesel
Displacement	121 in <sup>3</sup> (1.9 ltr)
Bore/Stroke	3.30/3.50 in (84/90 mm)
HP @ RPM	26/1800 19.5/1500
<b>Approx. fuel use</b>	
1800 RPM @ full load <sup>2</sup>	1.4 gph (5.2 lph)
1800 RPM @ half load <sup>2</sup>	0.83 gph (3.1 lph)
1500 RPM @ full load <sup>2</sup>	1.05 gph (3.97 lph)
1500 RPM @ half load <sup>2</sup>	0.62 gph (2.35 lph)
<b>Installation Data &amp; Weight</b>	
Wet exhaust elbow	2 inch (51 mm) OD
Raw water inlet	3/4 inch (19 mm) OD
Fuel inlet and return	1/4 inch NPT
Approximate dry weight	875 lbs (497 kg)

1. Based on SAE J1195 and ISO 3046.  
2. Actual fuel consumption will vary depending on operating conditions

## M844W2 Dimensional Drawing

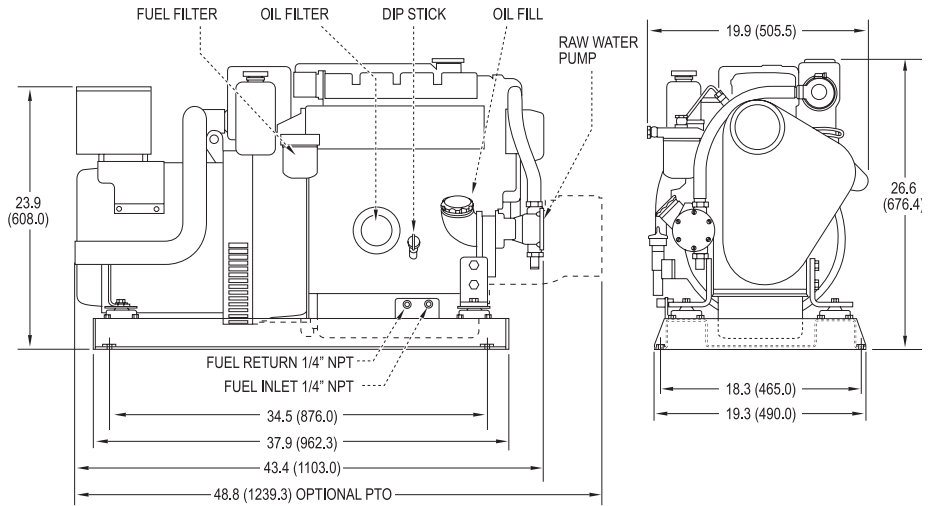

**M844W2 Overall Dimensions L x W x H:** 43.4 x 19.9 x 26.6 inch (1103 x 505.5 x 676.4 mm)  
Dimensions given in inches (mm). Dimensions subject to change without notice.  
Contact dealer or visit [www.northern-lights.com](http://www.northern-lights.com) for most current installation drawings.

## M844W2 Features and Benefits

### Engine Block

- Four cycle, 4 cylinder, liquid cooled, naturally aspirated, overhead valve diesel.
- Swirl combustion chambers improve fuel efficiency and reduce smoke.
- Glow plugs for quick cold starting.

### Cooling System

- Freshwater cooling system in heat exchanger or keel cooled configuration.
- One-piece heat exchanger, expansion tank and liquid cooled exhaust manifold. Fewer troublesome hoses and gaskets. Cast iron to resist corrosion and electrolysis.
- Heat exchanger cooling is standard. Tube-type heat exchanger has removable ends for easy cleaning. Easily accessible, rubber impeller, seawater pump of bronze and stainless steel is gear driven; no belt.

### Fuel System

- Fuel system is self-venting.
- Injection pump with 5% mechanical governor for close AC frequency control.
- Pintle injectors with replaceable tips.
- Mechanical lift pump with hand primer. No electric pump to fail.
- Large spin-on fuel filter.
- Flexible fuel lines routed to fuel manifold.
- Stop solenoid controls the fuel rack, not throttle, to eliminate speed variance and linkage problems.

### Intake and Exhaust

- Meets US EPA Tier II emission requirements.
- Washable air cleaner in cast intake manifold reduces intake noise.
- Cast iron, wet exhaust elbow for safety.

### Lubrication System

- Full flow, spin-on oil filter with bypass.
- 8.6 qt. (8.2 ltr) oil capacity for better lubrication. 200 hr oil change intervals.
- Oil drain for quick, clean oil changes.
- Crankcase vapor trap. Clean engine room.

### DC Electrical System

- DC system uses reliable relays instead of unrepairable printed circuit board.
- 12 volt starter motor and battery charging alternator with regulator and belt guard.
- Standard panel:  
Remote mount  
S-1B has hour meter, stop-start switch with run light and preheat switch.
- Expandable to six panels up to 110 ft from the generator set.
- 20 foot (6 m) plug-in panel harness lets you mount your panel anywhere onboard. Better than a inaccessible unit mount panel that is prone to vibration problems.
- Low oil pressure, high coolant and exhaust temperature shutdowns are standard.



### AC Generator

- Northern Lights, direct coupled, brushless AC generator is maintenance free. 4 lead-1 phase 50 or 60 Hz output is standard. 12 lead-3 phase optional. Conservative heat rise rating: 95°C/50°C ambient.
- Automatic Voltage Regulator is powered by dedicated AC winding for true 300% short circuit capability. Quick ±1% RMS no load to full load voltage regulation. AVR has circuit breaker protection

- Generator has high quality class "H" epoxy insulation, accessible diodes, over-sized bearing and junction box for AC wiring.

### Special Equipment

- Welded steel base frame with drip pan.
- Four platform mounts isolate vibration.
- White, long-life polyurethane paint.
- Operator's and parts manuals standard.

### Classification Standards

- Contact factory for details.



### Optional Equipment

- See accessory brochure for a complete list of customizing equipment.
- Front power take off with electric clutch
- Control panels with DC and AC gauges.
- 24 volt DC isolated or standard ground.
- Wire harness extensions and "Y" harness.
- 2 inch wet exhaust muffler.
- Exhaust / water separator.
- Keel cooling configuration.
- Alarms/shutdowns for low oil level, low coolant level, raw water flow and overspeed.
- Dry exhaust elbow.
- Onboard parts kits.
- Fuel filter-water separators.
- Shore power switches.
- Sound enclosure has powder coated marine aluminum panels lined with sound barrier foam to dampen noise. Trigger latches for easy access.



LxWxH: 49.91 x 27.16 x 29.74 in  
(1267.7 x 689.9 x 755.4 mm)  
Weight: 125 lbs (57 kg)

### Dealer

4420 14th Ave. NW., Seattle WA 98107  
Tel: (206) 789-3880 • 1-800-762-0165 • Fax: (206) 782-5455  
Information and dimensions subject to change without notice.  
Northern Lights and Lugger are registered trademarks  
of Alaska Diesel Electric, Inc.  
© 2005 All rights reserved. Litho USA. L675 03/05



[www.northern-lights.com](http://www.northern-lights.com)