

# Twin Disc Puts Ultimate Control In Your Hands

The EC200 Marine Electronic

Control System consists of cast

aluminum bronze control heads,

stainless steel control boxes,

and connected cables.



## Control Head Features

Sealed for water resistance

Adjustable lever tension

Triple detent with +/- 70° throw

Port and starboard neutral LEDs

Guarded station select pushbutton

Multi-function rotary switch

Port and starboard selected LEDs

Idle, sync and troll on panel selector

Optional grips and side panel  
inserts for custom appearance



## Control Box Features

Integrated power circuit breaker

12 and 24 volt versions available

Passivated stainless steel enclosure

Full setup from topside access panel

Fully connected for easy installation  
and service

The EC200 electronic control package is versatile, rugged and easy to install. The system is designed to interface with all popular mechanical and electronic engine and transmission systems. Access panel conveniently located on top surface of control enclosure permits easy setup and maintenance.

Options available include synchronization, trolling valve control, shaft brake control, and phantom lever controls for multi-engine systems. Control heads are available in chrome, natural gold tone, and black finish, with single and dual lever versions to accommodate all combinations of system options. Using the same control head and box hardware, special versions of the system are available for inboard engines, outboard engines, stern drive engines (I/Os), surface drive systems and waterjets.



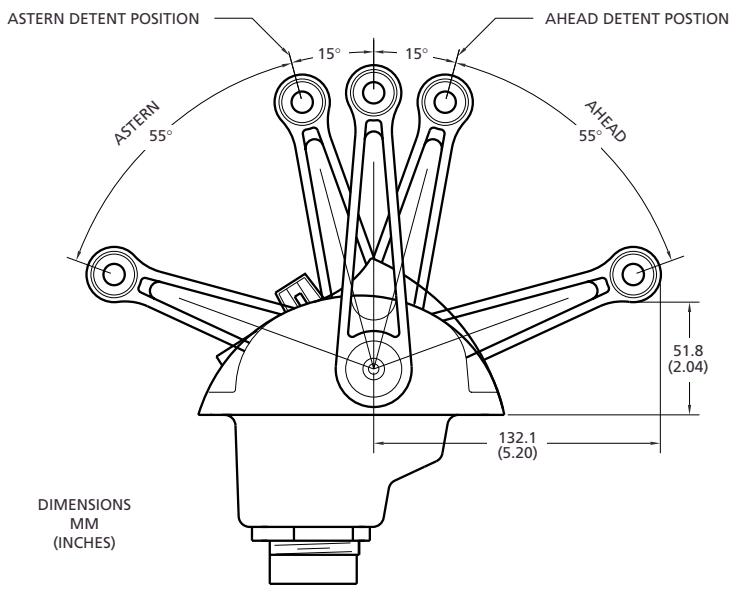

# EC200

